

DIMENSIONI D'INGOMBRO - OVERALL DIMENSIONS

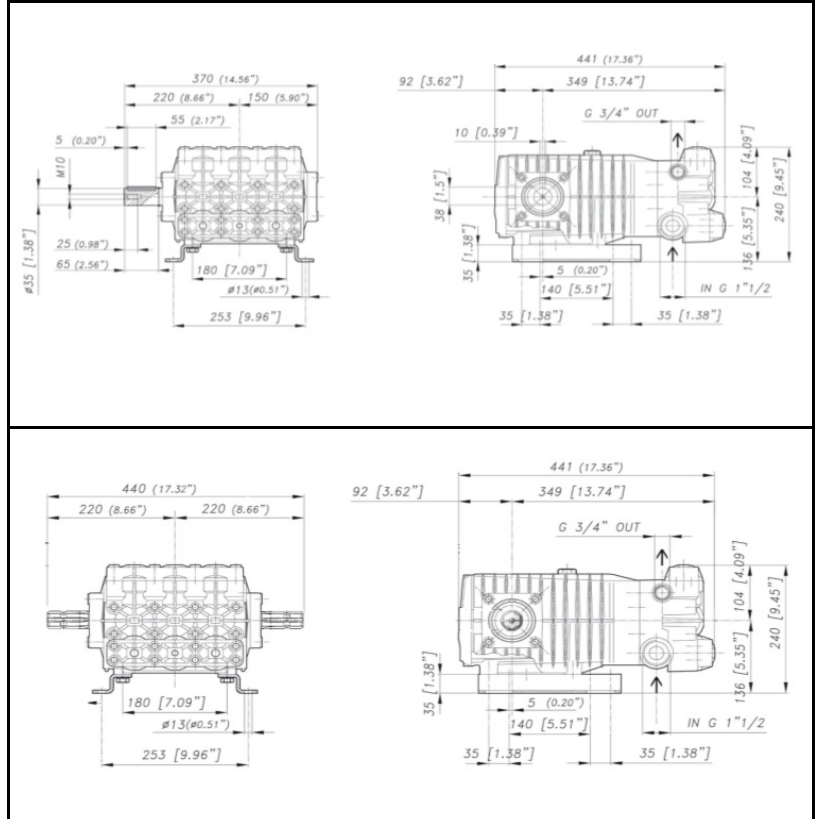

ALBERO POMPA - PUMP SHAFT

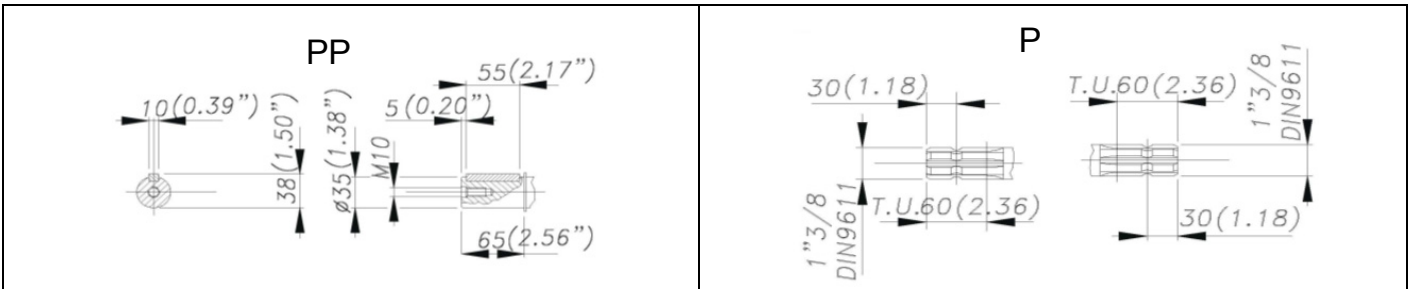

COPPIA DI SERRAGGIO - TORQUE CHART					
CODICE - CODE	Q.TY	POS	N-m	Lbr.ft	
86.3910.00.2	16	4	68	50,2	
86.4120.00.2	8	5	68	50,2	
86.3703.00.2	4	28	68	50,2	
86.3696.00.2	8	32	40	29,6	
86.2216.00.2	10	43	10	7,4	
86.3439.00.2	6	44	40	29,5	
86.3900.00.2	3	62	40 (LOXEAL 54-03)	29,6 (LOXEAL 54-03)	
73.0342.51.2	3	63	40 (LOXEAL 54-03)	29,6 (LOXEAL 54-03)	
Tolleranza di serraggio: 0/-10%					
Tolerance on torque value: 0/-10%					

INFORMAZIONI UTILI
USEFUL INFORMATION

LUBRIFICANTE- LUBRICANT:
OLIO MOTORE O SEMIIDRAULICO SAE 30
MOTOR OIL OR SEMI-HYDRAULIC OIL SAE 30

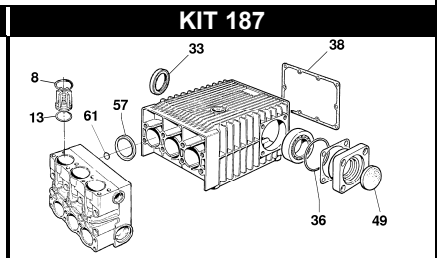
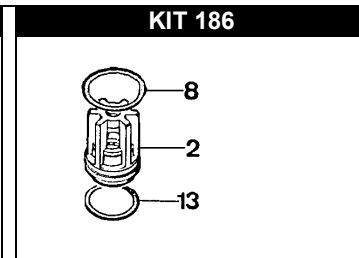
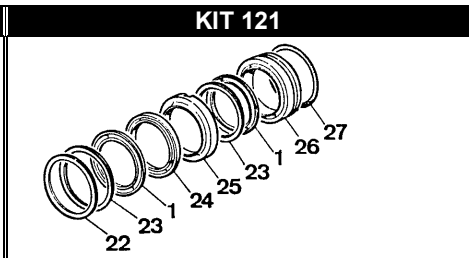
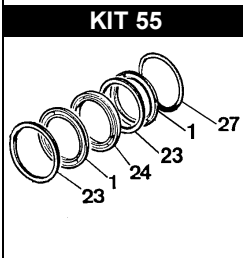
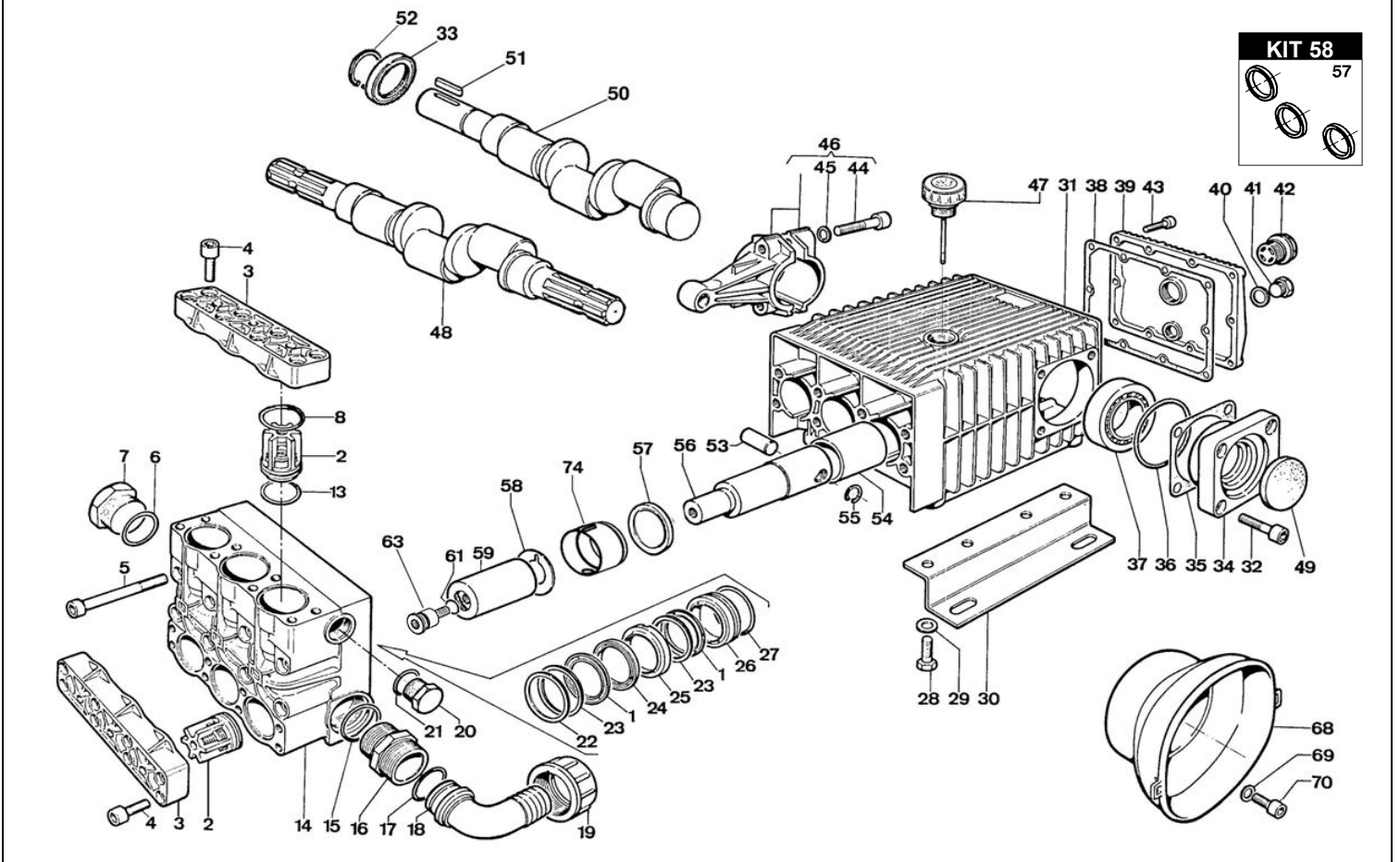

POS.	CODICE PART NO. RÉF.	DENOMINAZIONE - DESCRIPTION - DESCRIPTION	Q.TY
1	802201002	"V" PACKING DIA. D.45	6
2	739824973	VALVES ASSY	6
3	730416092	VALVES COVER	2
4	863910002	BOLT TCEI M12x40 UNI5931	16
5	864120002	BOLT TCEI M12x110 UNI5931	8
6	803265002	O-RING 2,62x47,3	1
7	852752002	CAP G. 1"1/2	1
8	803270002	O-RING 3,53x49,2	6
13	803253002	O-RING 3,53x34,52	6
14	730415092	PUMP HEAD	1
15	803265002	O-RING 2,62x47,3	1
16	835092502	NIPPLE G. 1"1/2-G. 1"3/4	1
17	803208502	O-RING 2,62x37,77	1
18	840595002	90° ELBOW CONNECTOR DIA.40 -1,57"	1
19	820095002	WING NUT G. 1"3/4	1
20	852693532	CAP G. 3/4	1
21	803218002	O-RING 3,0x22	1
22	730039532	SPACER	3
23	730044322	THRUST RING	6
24	730040322	ANTIEXTRUSION RING	3
25	730058532	FRONT GLAND	3
26	730070532	REAR GLAND	3
27	803283002	O-RING 3,53x58,74	3
28	863703002	BOLT	6
29	843906002	WASHER D.13 UNI1751	6
30	730024612	MOUNTING RAIL	2
31	730525092	CRANKCASE	1
32	863969002	BOLT TCEI M12x25 UNI5931	8
33	802143002	OIL SEAL	2-1
34/1	730411092	BEARING COVER D.80 CK 120 -CK 110	2
34/2	730412092	BEARING COVER D.72 CK 90-CK 115-CK 73	2
35/1	730413652	SHIM SP.0,1	1
35/2	730414652	SHIM SP.0,2	1
36	803210672	O-RING 2,62x88,57	2
37/1	812940002	BEARING 45X80X26 CK 120 -CK 110	2
37/2	812859002	BEARING 35X72X24 CK 90-CK 115-CK 73	2
38	730065722	COVER GASKET	1
39	730002092	CRANKCASE COVER	1

POS.	CODICE PART NO. RÉF.	DENOMINAZIONE - DESCRIPTION - DESCRIPTION	Q.TY
40	824107002	GASKET D.16,5x23x1	1
41	852579002	CAP G.3/8	1
42	853515502	OIL SIGHT GLASS WITH O-RING	1
43	862216002	BOLT TCEI M6x25 UNI5931	10
44	863439002	BOLT TCEI M10x45 UNI5931	6
45	843870002	SCHNORR WASHER D.10,5	6
46	739802973	CONROD	3
47	853516002	OIL PLUG + DIP STICK	1
48/1	730030262	CRANKSHAFT CK 73 P	1
48/2	730032262	CRANKSHAFT CK 110 P	1
48/3	730408262	CRANKSHAFT CK 120 P	1
49	802099602	CAP D.52x7	1
50/1	730409262	CRANKSHAFT CK 120 PP	1
50/2	760029262	CRANKSHAFT CK 110 PP	1
50/3	730319262	CRANKSHAFT CK 90 PP	1
50/4	730037262	CRANKSHAFT CK 73 PP-CK115 PP	1
51	806585002	TAB 10x8x55	1
52	801264002	SNAP RING D.35	1
53	852007402	PISTON PIN DIA.18x35	3
54	804470002	BUSHING	3
55	800040002	SNAP RING D.18	6
56	730407092	PLUNGER ROD	3
57	802180002	OIL SEAL	3
58	844301002	SPLASH GUARD WASHER	3
59	730410182	CERAMIC PISTON DIA.45	3
61	803195502	O-RING 2,62x20,24	3
63	730542512	PISTON HOLDING SCREW M12 (FROM 04/2019)	3
68	311482322	PLAIN SAFETY CONE (OPTIONAL)	1
69	843710002	WASHER DIA.9X24X2 UNI 6593 (OPTIONAL)	2
70	862475002	BOLT M8X14 UNI 5931 (OPTIONAL)	2
74	730528322	OIL SEAL SPACER (FROM 09/13)	3
REPAIR KIT	ITEM NO.s INCLUDED		P.CS.
KIT 55	739841973	SPARE PARTS KIT	18
KIT 58	739842973	SPARE PARTS KIT	3
KIT 121	739846973	SPARE PARTS KIT	27
KIT 186	739871973	SPARE PARTS KIT	18
KIT 187	731028973	SPARE PARTS KIT	24