

customized highest state PRECISIONIAL OF THE ART TML highest customized QUALITY PRECISION

CARATTERISTICHE - SPECIFICATIONS

IN	DIAMETER	\varnothing	1/2 BSP
	PRESS.	Min.	- 0.1 bar - 1.5 PSI
		Max.	6 bar 87 PSI
TEMP.	Max.	60° C. 140° F.	
OUT	DIAMETER	\varnothing	3/8 BSP
SHAFT		\varnothing	24 mm
OIL		SAE 75W 90	0.7 litri 0.18 U.S.G.
PESO WEIGHT		Kg / lbs	9.5 / 21



OPTIONAL



KIT PIEDINI cod. 07.9802.97.3 (optional)
MOUNTING RAILS KIT cod. 07.9802.97.3 (optional)
KIT SUPPORTS cod. 07.9802.97.3 (option)
JUEGO DE PIES cod. 07.9802.97.3 (opción)

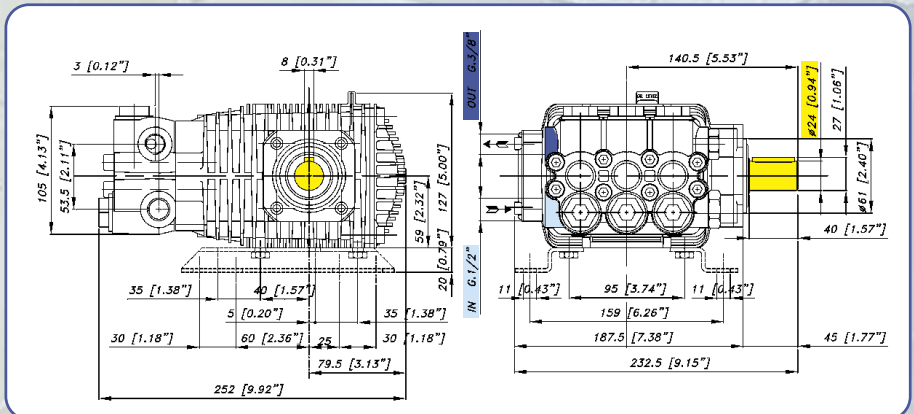

CARATTERISTICHE - FEATURES

PERFORMANCE CHART

MODELLO MODEL CODICE PART NR.	MAX		PRESS		RPM 950				RPM 1450				RPM 1725				PIST. PLUNG. Dia. mm	CORSA STROKE mm
	L/min	GPM	Bar	PSI	L/min	GPM	KW	HP	L/min	GPM	KW	HP	L/min	GPM	KW	HP		
TML 1220 07.1000.97.A	13.7	3.6	150	2175	7.7	2.0	2.3	3.0	12.1	3.1	3.4	4.6	13.7	3.6	4.0	5.4	18	11.2
			180	2610	7.7	2.0	2.7	3.6	12.0	3.1	4.1	5.5	13.6	3.6	4.8	6.5		
			200	2900	7.6	2.0	3.0	4.0	12.0	3.1	4.5	6.1	13.6	3.6	5.3	7.1		
TML 1320 07.1001.97.A	15.2	4.0	150	2175	8.5	2.3	2.5	3.4	13.1	3.4	3.8	5.1	15.2	4.0	4.5	6.0	18	12.4
			180	2610	8.5	2.2	3.0	4.0	13.0	3.4	4.5	6.1	15.1	4.0	5.3	7.2		
			200	2900	8.4	2.2	3.3	4.4	13.0	3.4	5.0	6.7	15.0	4.0	5.9	7.9		
TML 1520 07.1002.97.A	17.6	4.7	150	2175	9.9	2.6	2.9	3.9	15.1	4.0	4.4	5.9	17.6	4.7	5.2	7.0	18	14.4
			180	2610	9.8	2.6	3.5	4.7	15.0	4.0	5.3	7.1	17.5	4.6	6.2	8.3		
			200	2900	9.8	2.6	3.8	5.2	15.0	4.0	5.8	7.8	17.4	4.6	6.8	9.2		
TML 1720 07.1004.97.A	19.6	5.2	150	2175	11.0	2.9	3.2	4.3	17.1	4.5	4.9	6.6	19.6	5.2	5.8	7.7	18	16
			180	2610	10.9	2.9	3.9	5.2	17.0	4.5	5.8	7.8	19.5	5.1	6.9	9.2		
			200	2900	10.9	2.9	4.3	5.7	17.0	4.5	6.5	8.7	19.4	5.1	7.6	10.2		
TML 2020 07.1006.97.A	22.9	6.0	150	2175	12.8	3.4	3.8	5.1	20.1	5.2	5.7	7.7	22.9	6.0	6.7	9.0	18	18.7
			180	2610	12.8	3.4	4.5	6.1	20.0	5.2	6.8	9.2	22.8	6.0	8.0	10.8		
			200	2900	12.7	3.4	5.0	6.7	20.0	5.2	7.6	10.1	22.6	6.0	8.9	11.9		

highest quality state of the art
 customized precision
TML

CARATTERISTICHE - SPECIFICATIONS

IN	DIAMETER	\varnothing	1/2 BSP
	PRESS.	Min.	- 0.1 bar - 1.5 PSI
		Max.	6 bar 87 PSI
TEMP.	Max.	74° C. 165° F.	

OUT	DIAMETER	\varnothing	3/8 BSP
-----	----------	---------------	---------

SHAFT		\varnothing	24 mm
-------	---	---------------	-------

OIL		SAE 75W 90	0.7 litri 0.18 U.S.G.
-----	---	------------	-----------------------

PESO WEIGHT		Kg / lbs	10 / 22
-------------	---	----------	---------



INTELLiSeal™



OPTIONAL



INTELLiSeal HW™

- KIT PIEDINI cod. 07.9802.97.3 (optional)
- MOUNTING RAILS KIT cod. 07.9802.97.3 (optional)
- KIT SUPPORTS cod. 07.9802.97.3 (option)
- JUEGO DE PIES cod. 07.9802.97.3 (opcion)

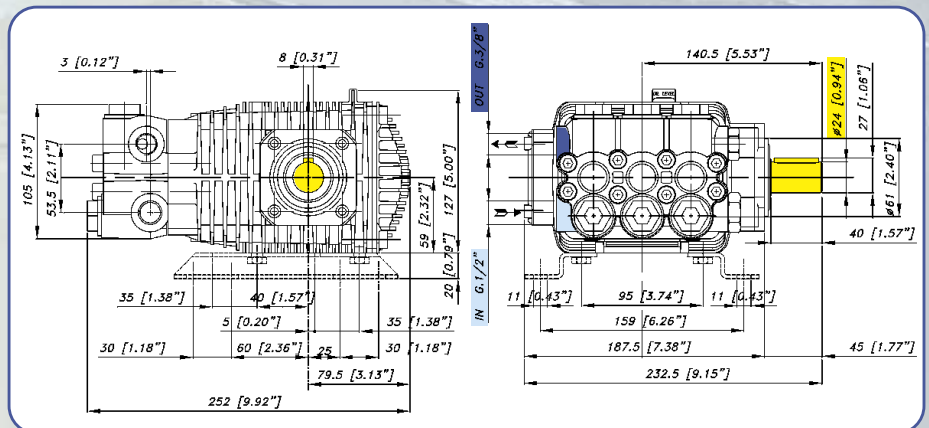

CARATTERISTICHE - FEATURES

PERFORMANCE CHART

MODELLO MODEL CODICE PART NR.	MAX		PRESS		RPM 950				RPM 1450				RPM 1725				PIST. PLUNG. Dia. mm	CORSA STROKE mm
	L/min	GPM	Bar	PSI	L/min	GPM	KW	HP	L/min	GPM	KW	HP	L/min	GPM	KW	HP		
TML 2120 07.1028.97.3	24.2	6.4	160	2320	13.6	3.6	4.3	5.7	21.1	5.5	6.4	8.6	24.2	6.4	7.6	10.2	20	16
			180	2610	13.5	3.6	4.8	6.4	21.0	5.5	7.2	9.7	24.0	6.4	8.5	11.4		
			200	2900	13.4	3.5	5.3	7.1	21.0	5.5	8.0	10.7	23.9	6.3	9.4	12.6		
TML 2420 07.1029.97.3	24.0	6.3	160	2320	15.9	4.2	5.0	6.7	24.0	6.3	7.5	10.1	N.D. N.A.	20	18.7			
			180	2610	15.8	4.2	5.6	7.5	23.9	6.3	8.4	11.3						
			200	2900	15.7	4.1	6.2	8.3	23.9	6.3	9.3	12.5						